



TRAVEL'R ARMS AND CANOPY

THIS MANUAL PROVIDES INSTRUCTIONS FOR ORIGINAL EQUIPMENT MANUFACTURER (OEM), AFTERMARKET INSTALLATIONS AND ARM UPGRADES FOR CURRENT CAREFREE AND A&E AWNINGS

RV



TABLE OF CONTENTS

Product Overview 1
 Travel'r Patio Awning Specifications: 1
 Component Checklist..... 2

Installation 3
 Required Pre-Installation Preparation..... 3
 Installing an Awning Rail..... 4
 Assembling the Awning 5
 Mounting the Awning 6
 Switch and Wiring Installation..... 7
 Securing the Fabric..... 8
 Removing the Temporary Assembly Pins..... 10
 Installing the Tractioners..... 10
 Attaching the Fascia 10

PROPRIETARY STATEMENT

The Travel'r Patio Awning is a product of Carefree of Colorado, located in Broomfield, Colorado, USA. The information contained in or disclosed in this document is considered proprietary to Carefree of Colorado. Every effort has been made to ensure that the information presented in the document is accurate and complete. However, Carefree of Colorado assumes no liability for errors or for any damages that result from the use of this document.

The information contained in this manual pertains to the current configuration of the models listed on the title page. Earlier model configurations may differ from the information given. Carefree of Colorado reserves the right to cancel, change, alter or add any parts and assemblies, described in this manual, without prior notice.

Carefree of Colorado agrees to allow the reproduction of this document for use with Carefree of Colorado products only. Any other reproduction or translation of this document in whole or part is strictly prohibited without prior written approval from Carefree of Colorado.

SAFETY INFORMATION

WARNING

A WARNING INDICATES A POTENTIALLY HAZARDOUS SITUATION WHICH, IF NOT AVOIDED, COULD RESULT IN DEATH OR SERIOUS INJURY AND/OR MAJOR PROPERTY DAMAGE.

CAUTION

A CAUTION INDICATES A POTENTIALLY HAZARDOUS SITUATION THAT MAY CAUSE MINOR TO MODERATE PERSONAL INJURY AND/OR PROPERTY DAMAGE. IT MAY ALSO BE USED TO ALERT AGAINST UNSAFE PRACTICES.

NOTE: A note indicates further information about a product, part, or step.

Tip: A tip provides helpful suggestions.

Safety Notes:

- Always disconnect battery or power source before working on or around the electrical system.
- Always wear appropriate safety equipment (i.e. goggles).
- Always use appropriate lifting devices and/or helpers when lifting or holding heavy objects.
- When using fasteners, use care to not over tighten. Soft materials such as fiberglass and aluminum can be "stripped out" and lose the ability to grip and hold.

Reference Publications located @ www.carefreeofcolorado.com:

- 052540-002 Travel'r, Installation Manual
- 052540-102 Travel'r Arm Extension Installation Supplement
- 052540-201 Travel'r, Owner's Manual
- 052540-301 Travel'r, Service Manual

PRODUCT OVERVIEW

The Travel'r provides motorized awning comfort with Carefree's standards for looks, strength and dependability. It is the successful blend of style, quality and economy. The awning is available in two fixed pitch models.

The awning roller tube and arms are made from light weight, no-rust aluminum. The awning fabric is heavy weight vinyl.

Travel'r Patio Awning Specifications:

MAXIMUM EXTENSION:		8 foot	MAXIMUM LENGTH:		21 feet
PITCH:	FLAT	Fixed	DROP:	approximately 6 inches	
	STEEP	Fixed		approximately 33 inches	
Measurement is from centerline of Awning Rail to centerline of rollbar					
MOTOR:		Power: 10VDC–14VDC	Circuit Rating: 20 amp	motor mounted in arm	
POWER SOURCE:		Motor and controls are routed and hardwired into the vehicle's 12V system			
EXTEND ACTUATION:		Gas Shock			
POSITION CONTROL:		Motorized roll out/in			
CONTROLLER:		3 position, momentary ON, center OFF Switch			
COLOR:	Frame:	White, Black			
	Canopy:	Available in a Variety of fabrics and colors – refer to order sheet			

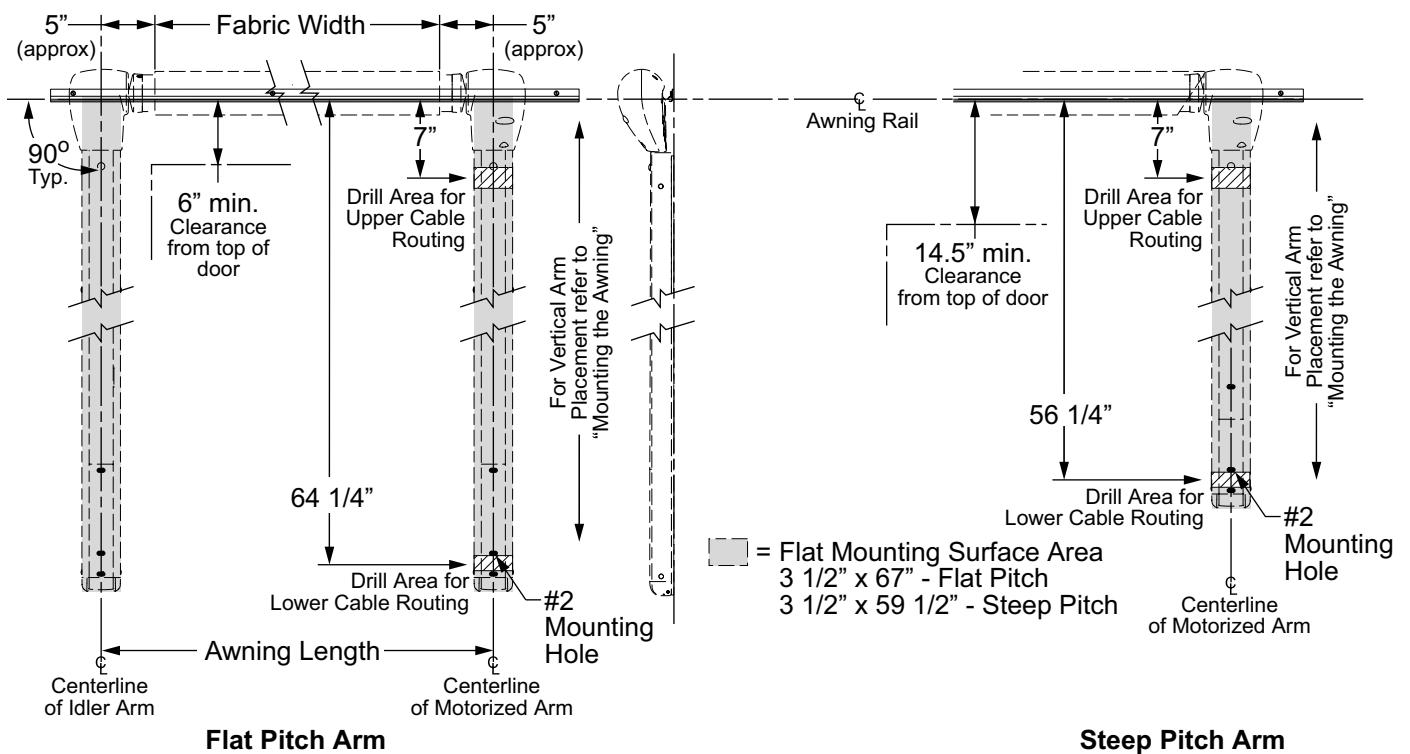

TravelR003

Figure 1. General Layout.

COMPONENT CHECKLIST

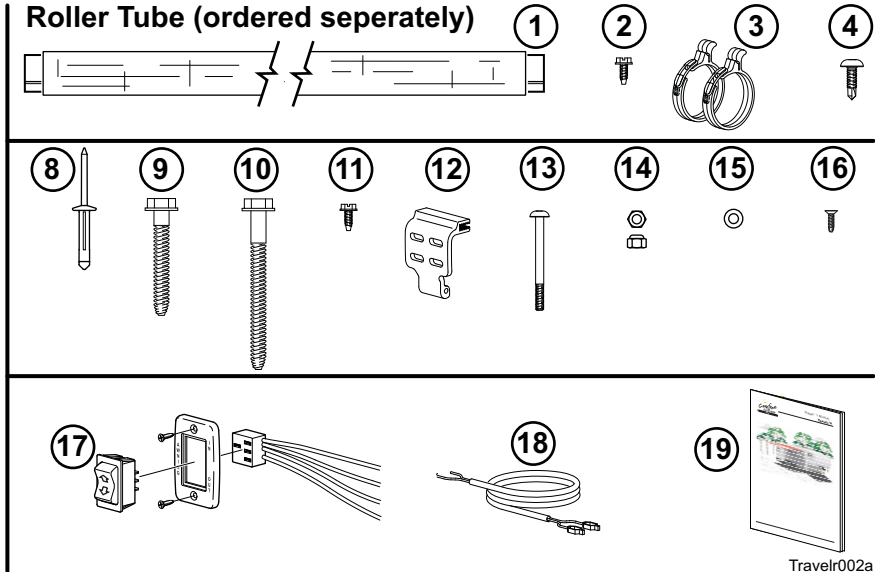
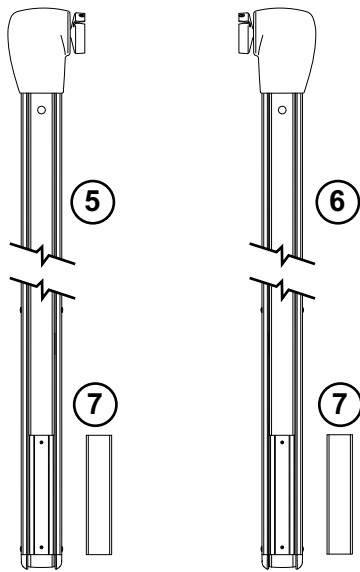

Figure 2. Component Checklist.

☑	ITEM	DESCRIPTION	QTY		NOTE
			A	B	
		A = OEM; B = Aftermarket			
<input type="checkbox"/>	1	Roller Tube Assembly	1	1	Ordered Separately
<input type="checkbox"/>	2	Screw, Hex Washer Head	2	2	#6 x 3/8
<input type="checkbox"/>	3	Tractioner	2	2	2
<input type="checkbox"/>	4	Screw, Truss Head, SQ Drive	2	2	#10 x 5/8
<input type="checkbox"/>	5	Arm Assembly, LH	1	1	1
<input type="checkbox"/>	6	Arm Assembly, RH	1	1	1
<input type="checkbox"/>	7	Fascia	2	2	3
<input type="checkbox"/>	8	Rivet, Moly	10	10	3/16
<input type="checkbox"/>	9	Screw, Lag	10	10	1/4 x 1 1/2
<input type="checkbox"/>	10	Screw, Lag	--	4	1/4 x 2 1/2
<input type="checkbox"/>	11	Screw, Truss Head, Sq Drive			#10 x 5/8
<input type="checkbox"/>	12	Screw, Hex Washer Head	2	2	#6 x 3/8
<input type="checkbox"/>	13	Top Mounting Bracket		2	
<input type="checkbox"/>	14	Screw, Phillips Pan Head		2	#10 x 2
<input type="checkbox"/>	15	Nylock Nut		2	#10
<input type="checkbox"/>	16	Washer, Plastic		8	#10
<input type="checkbox"/>	17	Switch,kit	1	1	
<input type="checkbox"/>	18	Jumper Cable	1	1	5
<input type="checkbox"/>	19	Owner's Manual	1	1	5

- Notes:
1. Awning configuration is specified at time of order, including awning length, fabric, color etc. Check awning assembly against original purchase order. Arms are configuration specific and are not interchangeable.
 2. Screws and Tractioners are furnished with rollbar assemblies equipped with optional Alumaguard.
 3. Fascia for the flat pitch is longer than the fascia for the steep pitch arms.
 4. Quantity for item 11 = 12 for flat pitch configuration, 8 for steep pitch configuration.
 5. Place Jumper Cable (item 18) and Owner's Manual (item 19) with RV owner information.

INSTALLATION

REQUIRED PRE-INSTALLATION PREPARATION

1. Park the vehicle on a flat surface and level the unit.
2. IF THIS IS AN UPGRADE FOR A MANUAL PATIO AWNING: follow the awning manufacturer's instructions and remove the awning from the coach including the roll bar and canopy.
 - a. Remove all brackets.
 - b. Plug and seal all mounting holes. The new Travel'r arms may not match the locations of the old awning arms.
 - c. Remove the roll bar from the arms and on a flat clean surface, roll the fabric onto the roll bar.
 - d. If the canopy is equipped with Alumaguard, remove the tractioners and set aside. These will be reinstalled after the new awning assembly is installed.
3. IF THIS IS AN UPGRADE FOR A ONE-TOUCH AWNING:
 - a. If the existing installation uses an external wall plug, the installer must furnish the mating plug for the new motor wires or remove the wall connector and wires. Plug and seal the hole then follow the standard wiring instructions.
 - b. Determine the existing wiring configuration:
 - *Configuration A* – Direct connection to switch. Motor wires connect directly to switch through the wall-mount connector. If the connector is retained (see step a), it is not necessary to remove the existing switch.
 - *Configuration B* – Control box electronics. A control box is installed between the connector and switches. Disconnect and remove the existing control boxes, wiring and switches. The system is replaced with the single switch control.
 - *Configuration C* – Auto Retract –All. Disconnect and remove the existing control boxes, wiring and switches. The system is replaced with the single switch control. Travel'r Direct Response Auto-Retract is available as a separate upgrade kit (SR0093) for the Travel'r Patio Awning.
 - c. Remove the awning from the coach including the roll bar and canopy.
 - d. Remove all brackets.
 - e. Plug and seal all mounting holes. The new arms may not match the locations of the old awning arms.
 - f. Remove the roll bar from the arms and on a flat clean surface, roll the fabric onto the roll bar.
 - g. If the canopy is equipped with Alumaguard, remove the tractioners and set aside. These will be reinstalled after the new awning assembly is installed.
4. For upgrades, follow the instructions for aftermarket installations.
5. Check where the awning arms will be installed. The arms fit snug to the side of the vehicle and must not cover or interfere with exhaust vents, lights etc.
6. If there is an awning rail installed, check that the awning rail runs the full length of the awning. Please refer to the note under "Installing an Awning Rail" before proceeding.
7. Refer to the important note on page 6 about the required positioning of the centerline of the roll bar.
8. For the bottom 3 mounting holes: if mounting into structure, use the 1/4 x 1 1/2 screws; if not attaching into structure, use the furnished moly rivets.

NOTE: The upper mounting holes (all configurations) MUST attach into structure using the screws provided.

***OEM Installations:* If structural backing is not available for the upper mounting holes, it will be necessary to use the aftermarket upper arm mounting bracket so that the upper brackets can mount into the structural members at the roof line.**

INSTALLING AN AWNING RAIL

NOTE: For canopies WITHOUT Alumaguard or Uniguard: If the vehicle already has a full-length awning rail installed, skip to step 5. The awning rail and arms must be positioned so that any existing trim does not interfere with the awning arm when in the closed position.

For Alumaguard and Uniguard installations: If the existing awning rail is incorporated into the coach trim or a drip rail, it will be necessary to mount a standard awning rail flat on the coach wall. The awning rail and arms must be positioned so that any existing trim does not interfere with the Alumaguard or Uniguard's "Flex Connect" or the awning arm when in the closed position.

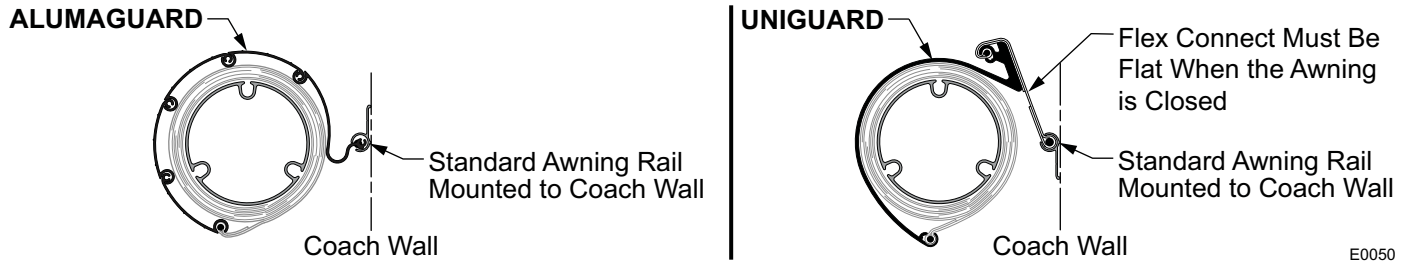

E0050

Figure 3. Fabric Wrap Positioning.

1. Determine the optimum positioning of the awning so that the arms will not interfere with the door frame or light fixtures. The centerline of the awning rail should be above the door opening a minimum of 6" for vinyl and 7" for Alumaguard/Uniguard. After determining mounting position, mark the position with a chalk line.
2. Awning rail must be level.
3. Seal the back of the rail with silicone sealant or putty tape.
4. Align the awning rail onto the wall and secure with #10 x 3/4" screws. Use all the attach holes in the rail.

CAUTION

MAKE SURE THE SCREWS ARE SECURELY MOUNTED TO THE STRUCTURAL FRAME OF THE VEHICLE.

5. Use a screwdriver to spread open one end of the awning rail on the installation side.
6. File any sharp edges or burrs from the end of the rail. This will help protect the awning fabric from damage during installation.
7. Spray inside the awning rail track with a dry silicone lubricant.

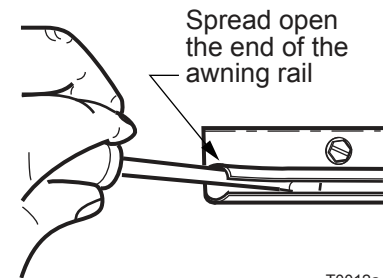

T0012a

Figure 4. Adjusting the Awning Rail.

STOP – If using the optional arm extension for mounting, follow the directions for "Assembling the Awning" and "Mounting the Awning" in Installation supplement 052540-102 - "Travel'r Arm Extension".

ASSEMBLING THE AWNING

1. Decide on the location of the switch to determine the cable routing.
2. If the motor cable is to be routed through the RV wall at the bottom of the arm, slip the cable through the slot at the bottom of the track (refer to Figure 10). Go to step 4.
3. If the motor cable is to be routed through the RV wall at the top of the arm:
 - 3.1 Remove the plastic wrap at the top of the motorized arm. Partially open the arm being careful to not let the arm extend more than 6".

NOTE: The arm is under tension from the gas shock located in the arm.

- 3.2 Pull the motor cable from the back of channel and out the hole in the top of the channel.
 - 3.3 Close the arm.
 - 3.4 Secure the top of the arm in the closed position using a plastic wrap or equivalent.
4. **For Aftermarket and Upgrade Installations:**
On each arm attach the top mounting bracket to the channel using the screw, nut and washers as shown.

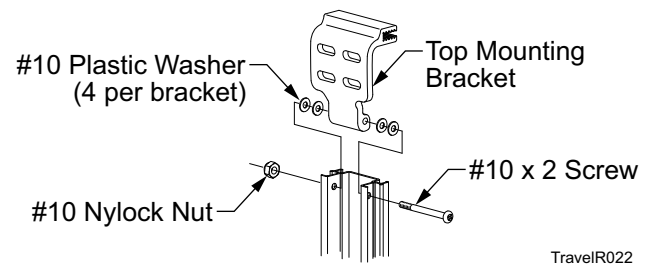

Figure 5. Aftermarket Top Mounting Bracket.

5. Align the roller assembly with the end cap on the motorized arm assembly. Rotate the end cap until the slot in the cap aligns with the empty slot in the roller assembly, and then press the roller assembly fully into the cap. The end cap must seat squarely over the end of the roller assembly when complete.
- NOTE: The roller assembly must be oriented with the fabric going over the roller toward the mounting surface.**
6. Secure the end cap to the roller assembly using two #10 square-drive screws.
 7. Repeat steps 5 and 6 to attach the non-motorized arm assembly to the roller assembly.

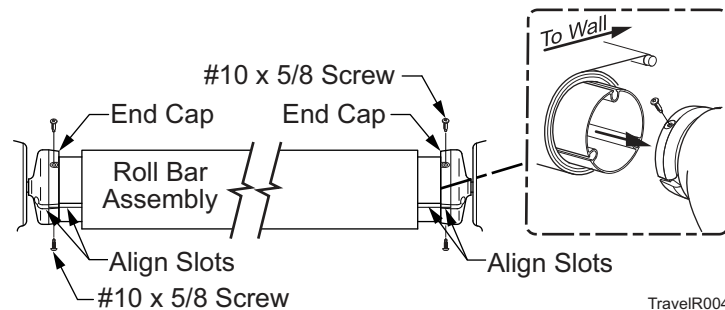

Figure 6. Assembling the Awning.

⚠ CAUTION

DURING ASSEMBLY AND INSTALLATION, THE ARM ASSEMBLIES MUST REMAIN PERPENDICULAR TO THE ROLLER ASSEMBLY. FAILURE TO HANDLE THE ARM ASSEMBLIES CAREFULLY CAN BEND THE DRIVE SHAFT.

MOUNTING THE AWNING

CAUTION

IT IS RECOMMENDED THAT AT LEAST THREE PEOPLE INSTALL THE AWNING DUE TO ITS SIZE AND WEIGHT.

(Refer to the General Layout in Figure 1 on page 1.)

1. Check the location the awning is to be mounted. Ensure that the awning will not interfere with other equipment on the vehicle, such as a slide out room, light fixtures, exhaust vents etc.
2. On the awning rail, mark the location of the centerline of the motorized arm assembly.
3. Unroll the canopy one wrap.

NOTE: While the awning fabric is fairly robust, care must be taken not to snag it on the awning rail.

4. With one person holding each arm, the third person should thread the polyrod (the plastic rod on the edge of the fabric) into the awning rail, starting at one end. Carefully move across the vehicle, gently pulling the fabric into the rail, until the awning is in the pre-determined location.
5. Position the motorized arm on the coach: Align the center of the motorized arm with the centerline marked in step 2. Butt the top of the rear channel against the awning rail as shown in Figure 7.

IMPORTANT NOTE: For Uniguard and Alumaguard installations, the centerline of the roll bar must be $3/4'' \pm 1/4''$ above the centerline of the awning rail. If the arm cannot be positioned as shown and meet this requirement because of trim below the awning rail, the installer must remove the trim where the arms mount or install a new awning rail below the trim.

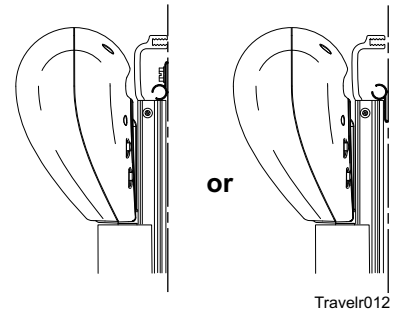

Figure 7. Vertical Arm Positioning.

6. Hold the arm assembly perpendicular to the awning rail and drill a $5/32''$ hole through the #2 mounting hole and attach the motorized arm using a $1/4 \times 1 \ 1/2''$ lag screw

NOTE: For the bottom 3 mounting holes: when attaching into structure, use $1/4 \times 1 \ 1/2$ screws; if not attaching into structure, use the furnished moly rivets. Moly rivets require a $1/4''$ hole in place of the $5/32''$ pilot hole.

The upper mounting holes (all configurations) must be attached into structure using the screws provided.

OEM Installations: If structural backing is not available for the upper mounting holes, it will be necessary to use the aftermarket top brackets to attach into the structural members at the roof line.

7. Confirm that the arm is perpendicular to the awning rail, attach the arm through the #1 mounting hole (shown in) using a 5/32" pilot hole and a 1/4 x 1-1/2" lag screw.
8. Position the roller assembly so that it is perpendicular to the motorized arm assembly. Position the non-motorized arm perpendicular to the roller assembly.
9. Drill a 5/32" hole through the #2 mounting hole and attach the non-motorized arm using a 1/4 x 1 1/2" lag screw.
10. Check the alignment; the arm assembly must be perpendicular to the roller assembly. When the alignment is correct, drill and attach the arm through the #1 mounting hole (shown in) using a 5/32" drill bit and a 1/4 x 1-1/2" lag screw.
11. Hold the awning closed and carefully remove the plastic wraps at the top of the arms. The awning will open a few inches.
12. Open the awning about 18" or until the top mounting holes on the arms are visible. To open
 - 12.1. Cap the exposed end of the wires from the motor cable to avoid grounding or shorting. These must remain capped and detached from the switch when using the emergency terminals.
 - 12.2. Attach the supplied jumper cables to the emergency terminals located on the back of the motorized head.
 - 12.3. Connect the other ends of the jumper leads to a 12V source (i.e. drill battery). If the awning does not begin to move, reverse the leads.

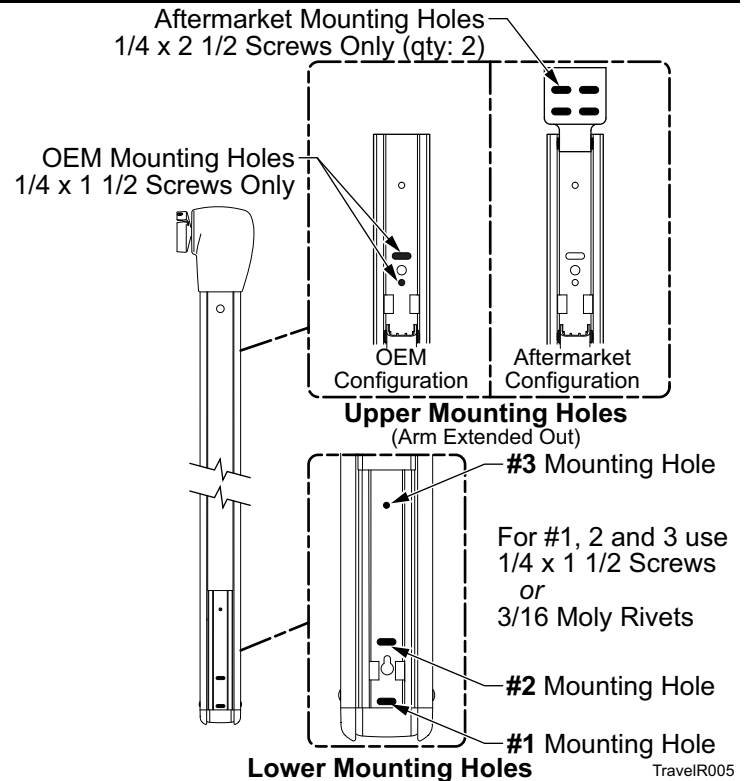

Figure 8. Arm Mounting Hole Locations.

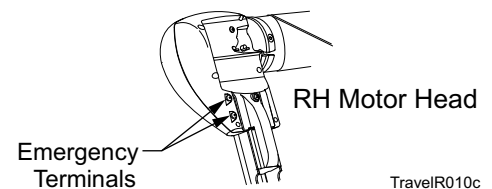

Figure 9. Emergency Terminals.

13. For Aftermarket configurations: Drill 5/32" pilot holes for the upper mounting holes through the bracket and the #3 lower mounting hole for each arm. Then attach the upper mounting bracket using 2 ea 1/4 x 2 1/2 lag screws. Attach the #3 lower mounting hole with a 1/4 x 1 1/2 lag screw or moly rivet.
14. For OEM configurations: Drill 5/32" pilot holes for the upper mounting holes then attach using 2 ea 1/4 x 1 1/2 lag screws. Attach the #3 lower mounting hole with a 1/4 x 1 1/2 lag screw or moly rivet.

SWITCH AND WIRING INSTALLATION

⚠ CAUTION Always disconnect the vehicle battery and electrical sources before working with the electrical wiring and components.

Notes:

1. Failure to follow the wiring instructions in this publication may void the motor warranty.
2. Do NOT wire two or more motors to one switch—No parallel wiring.
3. All wiring must conform to NEC (National Electrical Code) and local codes.

1. Determine the final location of the switch.

NOTE: If the distance from point of entry to the switch location is greater than 32" [81cm], the installer must furnish a splice between the motor cable and switch location.

2. FOR ONE-TOUCH UPGRADES:

2.1 If the external wall plug has been removed and sealed, go to step 3.

2.2 If using the wall plug, measure the motor cable from the arm to the plug. Trim the wire and terminate with an installer furnished mating connector. Attach the new connector to the wall plug and proceed to step 12.

3. For installations using the cable with a direct connection to the switch (no external plug).

3.1 (refer to Figure 10) Drill a 5/16" hole through the vehicle wall for the motor cable.

3.2 Route the cable through the hole to the switch location.

3.3 Seal the cable and hole using a silicone sealant.

4. At the switch location, cut a rectangular hole 1.25" [3.2cm] x 1.88" [4.8cm].

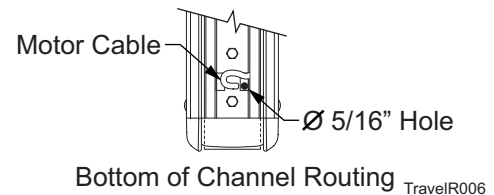
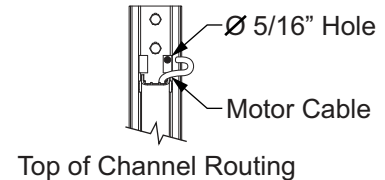
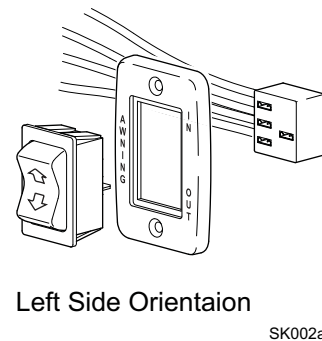
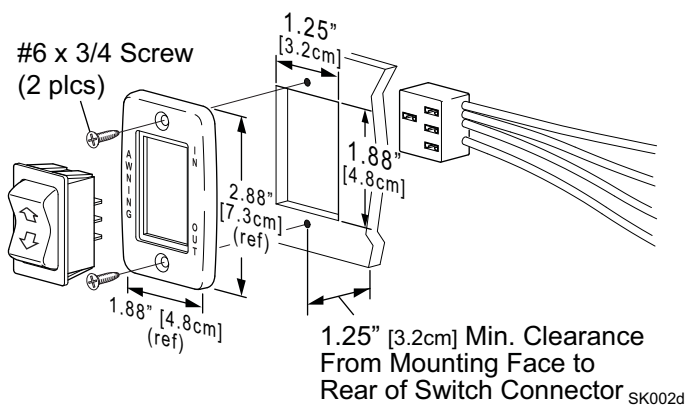

Figure 10. Cable Pass-thru Drill Pattern.



5. Determine the switch orientation:

5.1. The wires of the connector extend from the side of the switch with 3 terminals on the back.

5.2. For wire routing on the right side of the switch as shown in Details A and B, orient the switch with the 3 terminals on the right.

5.3. For wire routing on the left side of the switch as shown in Detail C, orient the switch with the 3 terminals on the left.

5.4. Push the switch into the faceplate until the tabs on the switch "click" into place behind the faceplate. Ensure that the switch and faceplate are oriented so that the lettering is up and the wires are oriented as desired.

5.5. Set switch aside.

6. Route the awning motor wires through the switch hole and attach to the switch connector:

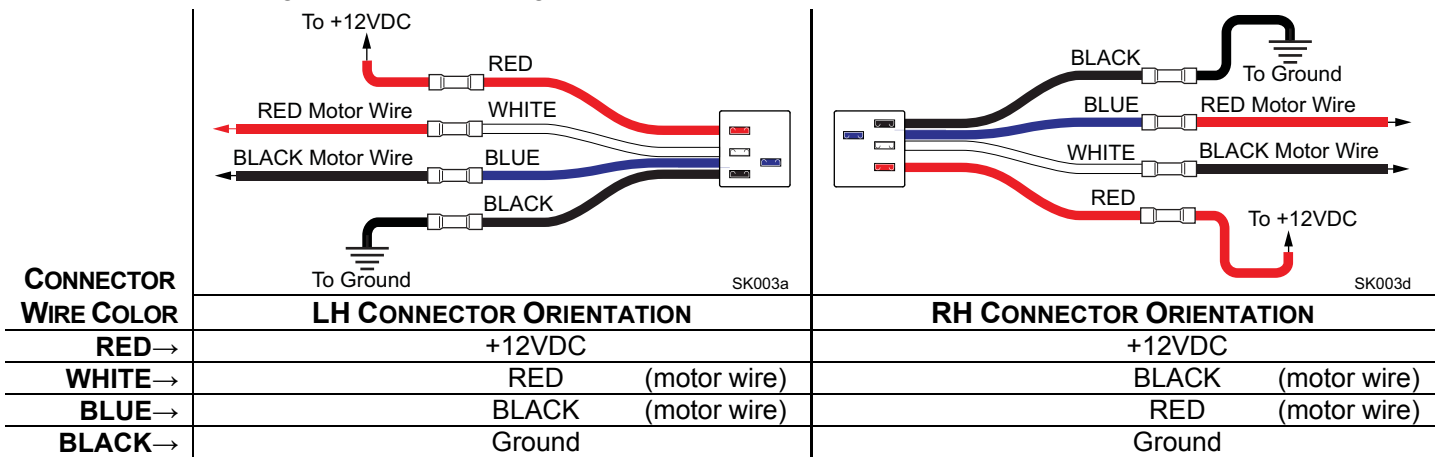

7. Run a minimum 16 awg wire from the power distribution panel (auxiliary battery circuit) or equivalent. The circuit should be protected by a 15-amp fuse.
8. Run a minimum 16 awg wire to system ground.
9. Route the two wires through the mounting hole. Butt splice the 12VDC wire to the RED connector wire. Butt splice the ground wire to the BLACK connector wire.
10. Attach the connector to the switch.
11. Restore power and test the switch operation.
12. If the awning operates opposite to the switch plate markings:
 - Shut off power;
 - Reverse motor wires connected to the blue and white connector wires;
 - Restore power and test.
13. Push the wires, connector and switch into the mounting hole and secure the switch plate. Use two (2) #6 x 3/4" flat head screws.

SECURING THE FABRIC

1. Roll the awning in and out several times to make sure that the fabric is square on the rollbar.
2. Secure the canopy using one, #6 x 3/8" hex head screw at both sides of the awning.

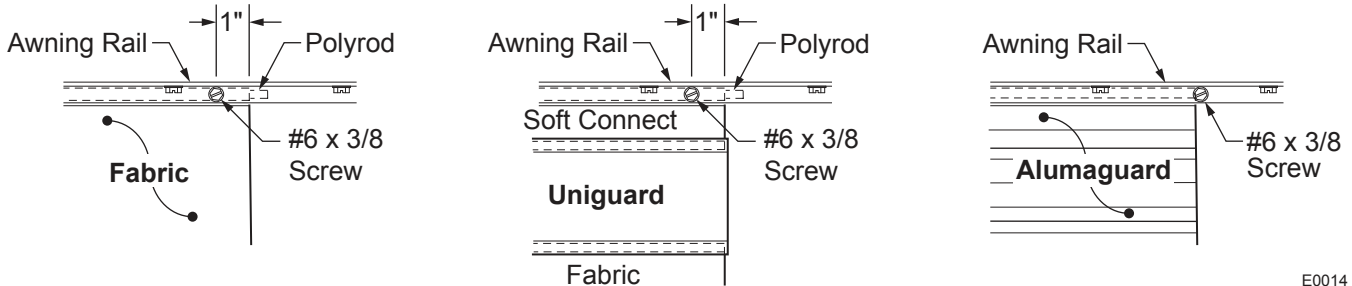

Figure 11. Securing the Fabric.

- 2.1 For vinyl awnings, place screw through awning rail, polyrod and canopy approximately 1" in from the end of the fabric.
- 2.2 For Uniguard awnings, place screw through awning rail, polyrod and the soft connect material approximately 1" in from the end of the fabric.
- 2.3 For Alumaguard awnings, place screw on the outer edge of the Alumaguard (not through the Alumaguard).

REMOVING THE TEMPORARY ASSEMBLY PINS

2 pins are inserted into the back of the left (idler) head for lateral stability during installation. Using a pair of pliers, remove and discard both pins.

NOTE: The awning will temporarily operate with the pins in place; however, for long term use the pins must be removed.

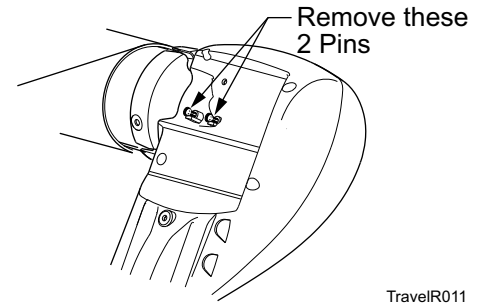

TravelR011

Figure 12. Remove the Assembly Pins.

INSTALLING THE TRACTIONERS

The tractioners are used with the Alumaguard and Uniguard metal fabric wraps.

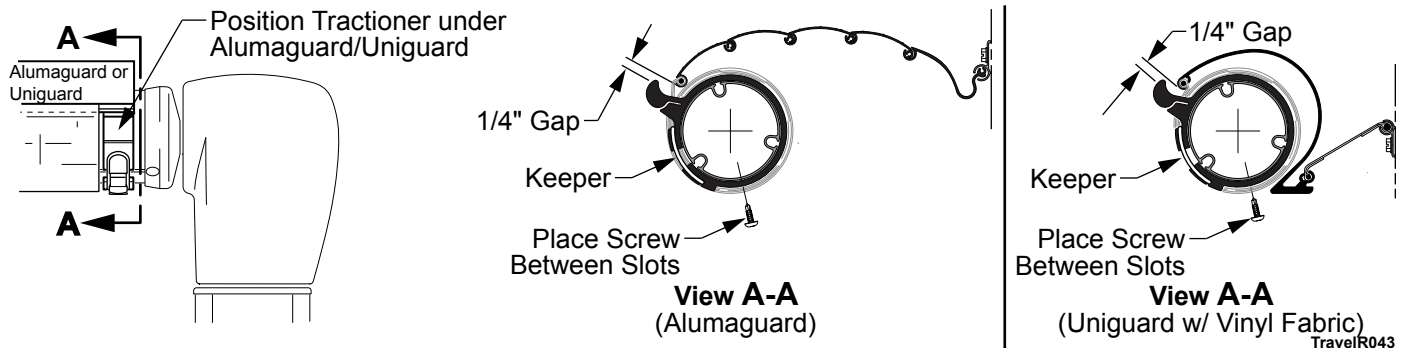

Figure 13. Installing the Tractioners.

1. Partially extend the awning until the Alumaguard/Uniguard is extended as shown.
2. Unlock the keeper and wrap the tractioner around the roller tube.
3. Position the tractioner under the Alumaguard/Uniguard with a 1/4" gap between Alumaguard and tractioner. Lock the keeper.
4. Repeat for the other end of the rollbar.
5. Extend the awning to verify that the tractioners are lifting the metal wrap up and over the roller assembly.
6. To secure the tractioner, drill a 1/8" hole through the tractioner and roller tube, roughly center the hole between two slots of the roller tube.
7. Secure with one (1) #10 square drive screw.

ATTACHING THE FASCIA

The fascia fits between the two struts of the lower arm.

1. If open, close the awning.
2. On the outer channels use a non-permanent method of marking and mark the bottom of the inner channel. Repeat for both arms.
3. Open the awning.
4. From behind, slip the fascia between the outer channels of the lower arm. Align the mounting slots of the fascia with the mounting holes in the outer channels.
5. Attach using #10 x 5/8 square-drive truss head screws.
6. Use the slots to adjust the position of the fascia to provide clearance for the arms to close. The top of the fascia should be approximately 1/8" below the marks made in step 2.

NOTE: The fascia for the flat pitch configuration uses 4 screws; the fascia for the steep pitch uses 2.

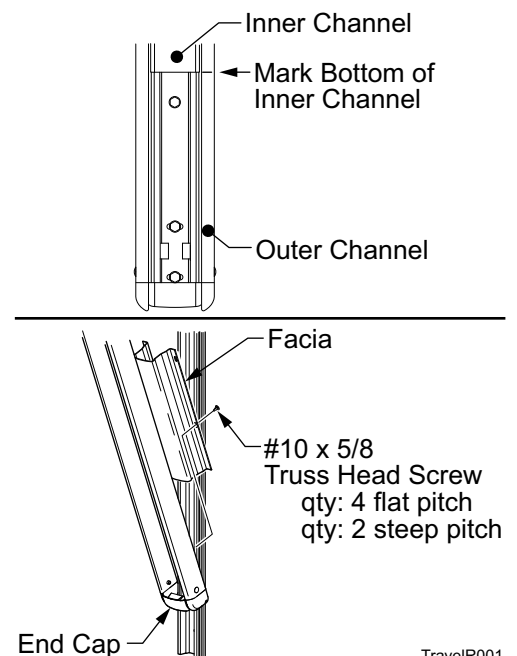

TravelR001

Figure 14. Attaching the Fascia.