



VILLA ROOM Owner's Manual

THIS MANUAL CONTAINS ORIGINAL INSTALLATION AND SETUP FOR:
VILLA ROOM FOR MOTORIZED AWNINGS
SNAPLESS UPGRADE KIT INCLUDED



FEATURES AT A GLANCE

VILLA ROOM SIDE PANELS	PRIVACY PANELS	35" COACH SKIRTING		SNAPLESS SIDE PANEL KIT
Fits rail heights up to 141"	Standard w/ Zippers	Standard		<i>Included</i>

These instructions apply to all configurations listed. Details and procedures unique to a specific configuration are labeled appropriately.

TABLE OF CONTENTS

First Time Preparation	1
.....
Motorized Awnings - Start Here	2
Installing the Snapless Brackets	3
Setting Up the Skirting	4
Setting Up the Room	5
Skirting	5
Install the Front Panel and Door - Motorized Awnings.....	6
Install the Side Panels – Steep Pitch Awnings	6
Install the Side Panels - Flat Pitch Awnings	7
Standard Maintenance	8
Storing the Panels	8
Fabric Care.....	8
Mildew	8
Component Check List	9
Limited Warranty	10

SAFETY INFORMATION

WARNING

A WARNING INDICATES A POTENTIALLY HAZARDOUS SITUATION WHICH, IF NOT AVOIDED, COULD RESULT IN DEATH OR SERIOUS INJURY AND/OR MAJOR PROPERTY DAMAGE.

CAUTION

A CAUTION INDICATES A POTENTIALLY HAZARDOUS SITUATION THAT MAY CAUSE MINOR TO MODERATE PERSONAL INJURY AND/OR PROPERTY DAMAGE. IT MAY ALSO BE USED TO ALERT AGAINST UNSAFE PRACTICES.

NOTE: A note indicates further information about a product, part, or step.

Tip: A tip provides helpful suggestions.

Safety Notes:

- Always wear appropriate safety equipment (i.e. goggles).
- Always use appropriate lifting devices and/or helpers when lifting or holding heavy objects.
- When using fasteners, use care to not over tighten. Soft materials such as fiberglass and aluminum can be "stripped out" and lose the ability to grip and hold.

FIRST TIME PREPARATION

The Villa Room panels include privacy panels to cover the screens. The front and side panels can be reversed: Place the privacy panels on the inside for secured privacy. *OR* Place the privacy panels on the outside for increased rain protection.

Illustrations in these instructions show the panels with the privacy panels on the outside of the room. To have the panels on the inside of the room, reverse the orientation of the insert and swap the left and right side panels.

MOTORIZED AWNINGS

NOTE: For motorized awnings, the zipper insert can remain on the roller tube and can be rolled up with the awning. After the first installation, the front panel can be removed by unzipping the panels from the insert.

1. Extend the awning out completely according to the manufacturer's instructions.
2. (*Detail A*) For Carefree electric awnings, it is necessary to over extend (reverse wrap) the fabric on the roller tube.

For Awnings without Auto Retract:

- Hold the EXTEND switch until the empty slot of the tube aligns with the slot on the back of the idler head.

For Awnings with Auto Retract:

- After extending the awning, press and release the retract button. Stop the awning when the roller tube makes approximately 1/2 turn or less.
- Hold the EXTEND switch until the empty slot of the tube aligns with the slot on the back of the idler head.

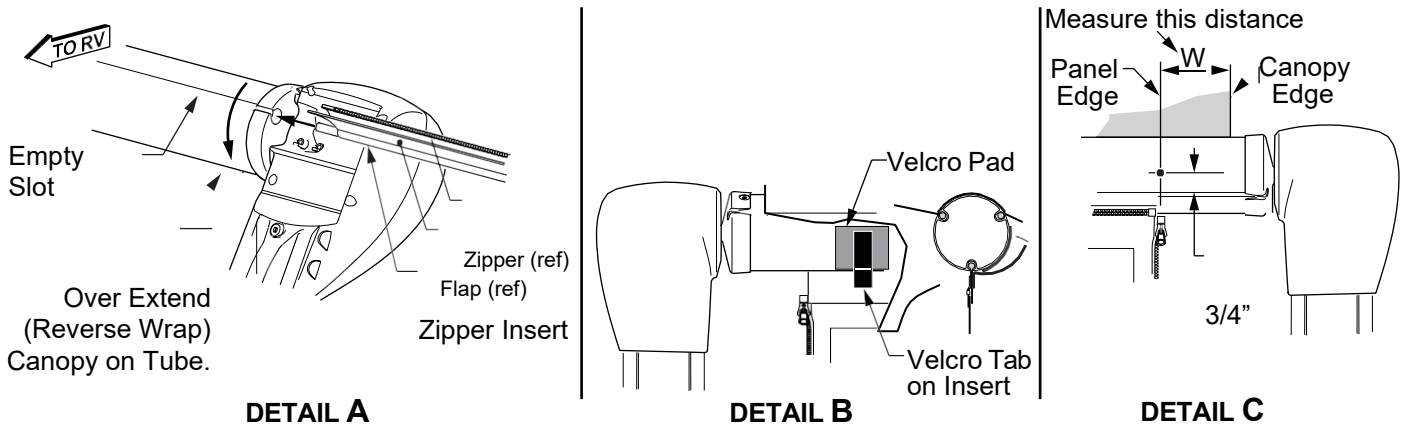

(View Looking at Back of Idler Head)

AAR021

Figure 1. Installing the Zipper Insert.

3. (*Detail A*) Slide the zipper inserts into the slot.
 - For the privacy panels on the inside of the room, slide the insert in with the zipper facing the RV. For the privacy panels on the outside of the room, slide the insert in with the flap facing the RV.
 - For the door on the right side, slide the short (door) zipper insert in first then the long (panel) zipper insert.
 - For the door on the left side, slide the long (panel) zipper insert in first then the short (door) zipper insert
4. Using the retract switch, roll the awning up to the normal extended position.
5. Zip the front panel and door to the zipper insert. Zip the door and front panel together.
6. Position the panel on the roller tube.
 - For full size rooms, center the panel and door beneath the awning canopy.

7. (Detail B) Place the square Velcro hook pieces on the roller tube to align with the Velcro tabs on the zipper inserts. Remove the backing paper and stick the velcro on the roller tube beneath the tabs.
8. The Villa Rooms comes with 2 sets of rafters, one set is for the snapless side option and the other set are the horizontal rafters for the side panels.

⚠ CAUTION

9. **The vertical rafters are only recommended with awnings that have steep pitch. If rafters are used on flat pitched awnings the awning can fill up with water and collapse.**
10. For steep pitch awnings (Detail C) on the roller tube, mark the edge of the zipper. Measure 3/4" up the roller tube from the slot with the zipper insert.
11. Drill a 5/16" hole into the rollbar. Clean and deburr the hole as required. Use care to not damage the canopy. *Tip: Use a punch or small drill bit to mark and start the hole.*
12. Measure and note the final distance (dimension "W") from the edge of the awning canopy to the center of the hole. This dimension will be used to mount the rafter brackets on the RV wall.
13. Repeat steps 9 & 10 for the other side.

INSTALLING THE Upper BRACKETS

⚠ CAUTION

THE SIDE PANELS MUST NOT INTERFERE WITH LP APPLIANCE OR EXHAUST VENTS.

These brackets are used with the Snapless Side Panel.

1. On the RV wall, measure in from the edge of the awning a distance equal to the dimension "W" measured previously.
2. Measure down 1" from the center of the awning rail. This is the position of the top of the bracket.
3. Using the bracket as a template, mark the location of the mounting holes then drill four (4) 1/8" pilot holes.
4. Coat the back of the bracket with a silicone sealant and attach the bracket to the wall using four (4) #8 x 3/4 hex head screws.
5. Using a non-permanent method of marking, mark center line of the bracket to the floor line. The centerline must be perpendicular to the awning rail.
6. At the floor line, attach the lower mounting bracket using two (2) each #8 x 3/4 hex head screws.

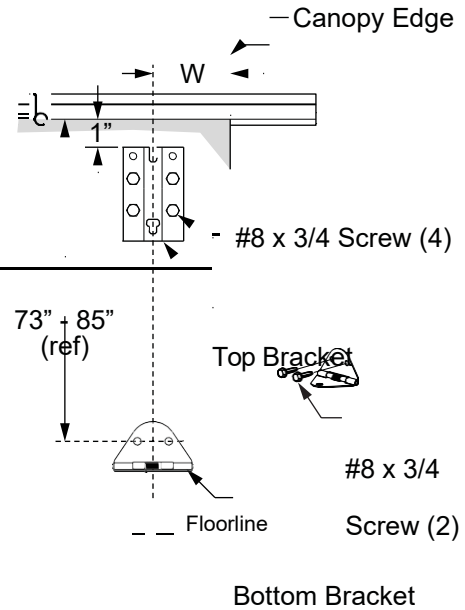

AAR003

Figure 3. Installing the Snapless Brackets.

NOTE: If the awning rail to floor line distance is outside of the 73"-85" range shown it will be necessary to adjust the location of the lower bracket to fit in this range. If the bracket is not mounted at the floor line, it must be mounted in a location with adequate backing.

SETTING UP THE SKIRTING

If the skirting crosses the entry step, extend the step. If so equipped, the automatic entry step operation should be disabled when installing and/or using the skirting.

⚠ CAUTION

THE SKIRTING MUST NOT INTERFERE WITH LP APPLIANCE OR EXHAUST VENTS. DO NOT START OR OPERATE THE MOTORHOME ENGINE OR RV GENERATOR IF THE EXHAUST COMPONENTS ARE LOCATED BEHIND THE SKIRTING.

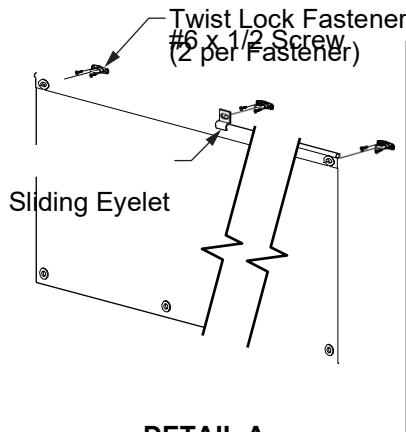

DETAIL A
(Installing the Twist Fasteners)

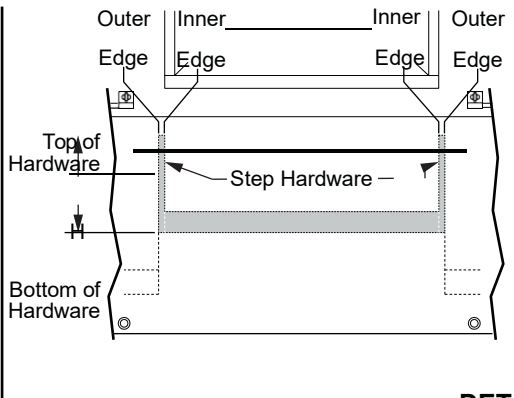

DETAIL B
(Cutting Out the Entry Step)

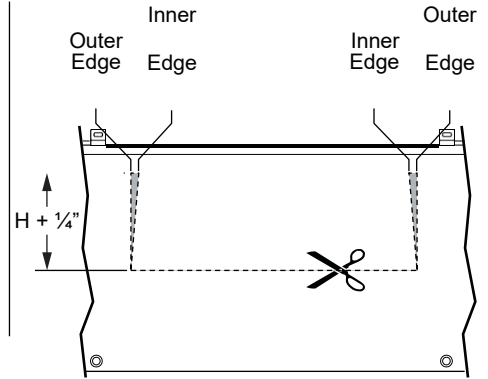



AAR004a

1. Position the skirt so that each end overlaps where the room walls will intersect with the RV wall. The wall will intersect with the RV at the center line drawn previously for mounting the wall brackets/fasteners.
2. Mark the location of one of the corner eyelets and install one twist fastener. The fastener must be located below the door opening and frame.
3. Attach the skirt to the fastener then pull the skirting taut and level with the lower trim and mark the location of the other end eyelet. Install a second twist fastener.
4. Slip the sliding eyelets onto the poly rod sewn onto the top of the skirt. Position the eyelets as required between doors. Mark the location.
5. Install twist fasteners at the locations marked.
6. **If the panel goes across the entry step: (Detail B)**
 - With the panel attached to the RV wall, carefully mark the location of the top, inner and outer edges of the step hardware.
 - Remove the skirt from the RV and layout on a flat clean surface.
 - Measure the height (H) of the step hardware.
 - On the skirt, measure the distance $H + 1/4"$ down from the mark made for the top of the hardware.
 - Using a straight edge and sharp knife, draw then cut out the two triangles on the skirt.
 - Draw and cut a straight line between the two lower points of the triangles. This creates a flap in the fabric.
 - Slide the skirting over the step and tuck the flap behind the stair tread. Attach the skirting to the twist fasteners.
7. Smooth the skirting so that it is hanging flat and straight.
8. Repeat steps 1-5 if installing the wheel well cover.

This completes the First Time Preparation for the Villa Room. If the room is not to be used immediately, remove and fold the insert (if installed), front panel, door and skirt. To setup the room for use, follow the instructions under "Setting Up the Room" on page 5.

SETTING UP THE ROOM

WARNINGS

-  AUTO-RETRACT SYSTEMS:** FOR AWNINGS WITH AUTO-RETRACT, THE AUTO-RETRACT FEATURE **MUST BE SHUT OFF**. IF THE AWNING SHOULD RETRACT AFTER THE ROOM IS SETUP, DAMAGE TO THE AWNING, ROOM AND RV WILL OCCUR AS WELL AS POSSIBLE PERSONAL INJURY. REFER TO THE AWNING OWNER'S MANUAL FOR INSTRUCTIONS.
-  AUTO-DUMP DISABLED:** THE AUTO-DUMP FEATURE, FOR AWNINGS SO EQUIPPED, IS **DISABLED** WHEN THE ROOM IS SETUP.
-  WATER POOLING:** FOR AWNINGS SET AT THE MINIMUM PITCH (I.E. FLAT PITCH), WATER POOLING CAN OCCUR DURING INCLIMATE WEATHER. TO PREVENT DAMAGE TO THE AWNING, DISMANTLE THE ROOM AND RETRACT THE AWNING.

Refer to your awning owner's manuals for additional information on auto-retract systems, auto-dump features and water pooling.

This section assumes that the steps under "First Time Preparation" have been completed. If not, it will be necessary to complete "First Time Preparation" before continuing.

SKIRTING

If the skirting crosses the entry step, extend the step. If so equipped, the automatic entry step operation should be disabled when installing and/or using the skirting.

CAUTION

THE SKIRTING MUST NOT INTERFERE WITH LP APPLIANCE OR EXHAUST VENTS. DO NOT START OR OPERATE THE MOTORHOME ENGINE OR RV GENERATOR IF THE EXHAUST COMPONENTS ARE LOCATED BEHIND THE SKIRTING.

1. Extend the entry step if applicable.
2. Slide the skirting over the step and tuck the flap behind the stair tread. Attach the skirting to the twist fasteners.
3. Smooth the skirting so that it is hanging flat and straight.
4. Repeat these steps for the wheel well cover if used.

INSTALL THE FRONT PANEL AND DOOR -

The zipper insert is left on the roller tube and can be rolled up with the awning. After the initial setup, the front panels are attached and removed by zipping or unzipping the panels and inserts.

1. Extend the awning out completely according to the manufacturer's instructions. Ensure that the zipper insert in the roller tube is down and accessible. It may be necessary to adjust the pitch later.
2. Zip the front panel and door to the zipper insert. Zip the door and panel together.

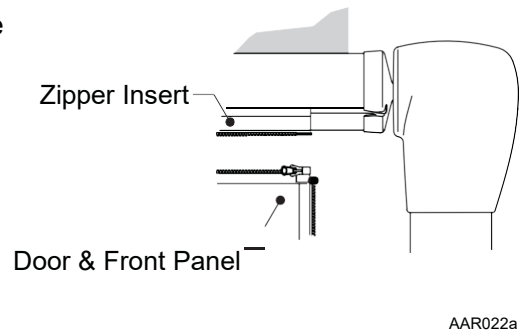

AAR022a

Figure 5. Attaching the Front Panel.

INSTALL THE SIDE PANELS – STEEP PITCH

1. Extend the rafter pole to its maximum length. To extend the pole, twist the inner (smaller) tube a quarter turn, lock in place with a reverse quarter turn.
2. (Detail A) Unfold the side panel and slide the rafter into the pocket at the top of the panel. The rafter pole hook goes to the back edge of the panel.

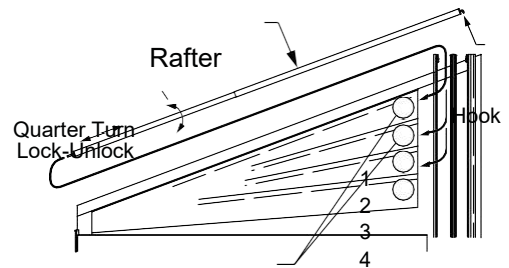

#2 for Acrylic canopies & canopies with Uniguard.

3. (Detail B) Lift the panel and rafter up and hook the rafter into the "U" slot of the mounting bracket on the RV wall.
NOTE: For awnings with Uniguard, the Uniguard will rest on top of the rafter when the rafter is installed.
4. (Detail C) Lift the front edge of the panel up, unlock the rafter pole then insert the pin into the mounting hole of the roller tube.
5. Extend and lock the rafter.
6. For adjustable pitch awnings: If necessary, adjust the pitch of the awning so that the side panel hangs with the back edge parallel with the coach wall.

Tip: After setting up the room, permanent mark the final awning arm pitch setting. The awning can be opened in the correct position and pitch for subsequent uses.

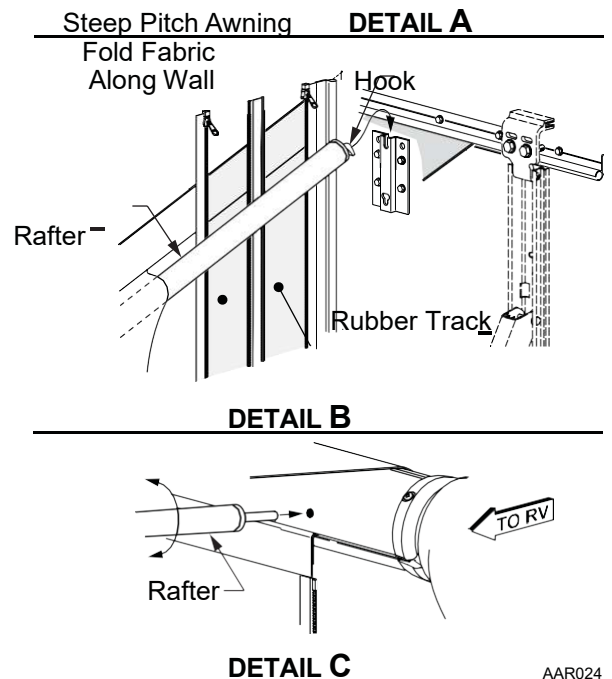

AAR024

Figure 6. Installing the Rafter and Side Panel.

7. Slide the pole assembly onto the pocket at the rear of the side panel. The hook goes to the top.
8. *(Detail C)* Holding the pole at an angle, hook the pole into the lower T-slot of the upper mounting bracket.
9. *(Detail D)* Rotate the pole down and align the lower pin with the lower bracket. Adjust the length of the pole to ensure a snug fit. Lock the pole with a quarter-turn twist of the bottom tube. Smooth the rubber seals against the RV wall.
10. Adjust the panel on the rafter pole and Snapless pole so that the panel is hanging straight.
11. Zip the side panel and front panel (or door) together. For tall flat pitch awnings with the front extension panel, attach the velcro between the expansion panel and side panel.
12. At the bottom of the panels and skirt, fold any excess material inside the room and secure the panels to the ground using stakes and the appropriate row of grommets.
13. Repeat on opposite side.

INSTALL THE SIDE PANELS – Flat PITCH

1. Slide the pole assembly onto the pocket at the rear of the side panel. The hook goes to the top. Pass the hook through the grommet at the top of the side panel.
2. *(Detail C)* Holding the pole at an angle, hook the pole into the lower T-slot of the upper mounting bracket.
3. *(Detail D)* Rotate the pole down and align the lower pin with the lower bracket. Adjust the length of the pole to ensure a snug fit. Lock the pole with a quarter-turn twist of the bottom tube. Smooth the rubber seals against the RV wall.
4. Adjust the panel on the rafter pole and Snapless pole so that the panel is hanging straight.
5. Wrap the strap over the roller tube and connect the buckle. Pull on the strap to tension the side panel. Zip the side panel and front panel (or door) together. For tall flat pitch awnings with the front extension panel, attach the velcro between the expansion panel and side panel.
6. At the bottom of the panels and skirt, fold any excess material inside the room and secure the panels to the ground using stakes and the appropriate row of grommets.
7. Repeat on opposite side.

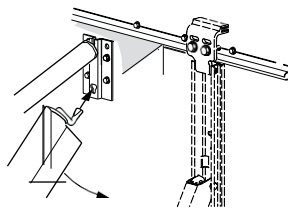

Panel Not Shown for Clarity

DETAIL C

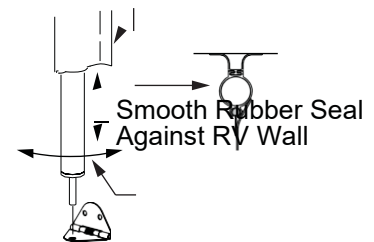

Quarter-Turn
Lock - Unlock

DETAIL D

STANDARD MAINTENANCE

Maintaining the VILLA ROOM is easy. Just follow these basic steps:

- Always set up the room according to the instructions.
- Periodically check that the fasteners are tight. Tighten if necessary.
- Keep the fabric and poles clean.

STORING THE PANELS

1. Ensure that the privacy panels are down and secured.
2. Remove the spikes holding the skirt panels.
3. Reverse the setup procedures to remove the panels, doors and poles. Store the hardware in the storage bags.
4. Fold the panels:
 - a) Lay the panels flat with the screen panel facing up.
 - b) Square the side panel by folding the triangular shape over.
 - c) Fold the top over and down to the bottom edge.
 - d) Fold in half again.
 - e) Starting on one end, fold the panel in approximately 12" segments.
 - f) Store the panels in the storage bags.

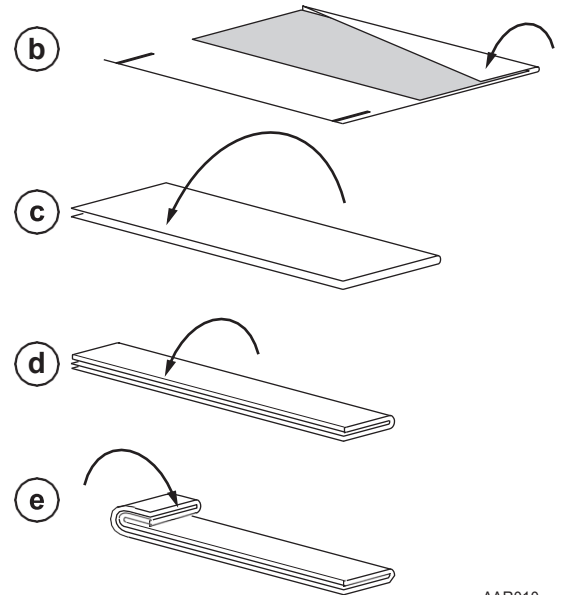

AAR010

FABRIC CARE

⚠ CAUTION

DO NOT USE OIL BASED CLEANERS OR ANY CAUSTIC, GRANULATED, OR ABRASIVE TYPE CLEANERS.

1. One of the best ways to keep the fabric looking good and to delay the need for deep or vigorous cleanings is to hose fabrics off on a monthly basis with clear water. This practice will help prevent dirt from becoming deeply imbedded in the fabric. In most environments, a thorough cleaning will be needed every two to three years.
2. When it is time for a thorough cleaning, the fabric can be cleaned while still on the awning frame. Use a soft brush and warm water with soap.
3. When cleaning the fabric, it is important to observe the following:
 - Always use a natural soap, never detergent.
 - Water should be cold to lukewarm, never more than 100°F.
 - Air-dry only. Never apply heat to the fabric.
 - Always allow the fabric to dry thoroughly before folding and storing.

Mildew

Mildew is a fungus growth that looks like dirt. Vinyl coated polyester fabrics are mildew resistant because of a chemical biocide in the vinyl coating. Under ordinary conditions, mildew will not appear. However, in areas where high temperature and humidity are common, mildew can be a problem and require the material to be washed more frequently. Thoroughly rinse the fabric with clean water and allow to air dry completely before folding and storing.

COMPONENT CHECK LIST

Use this packing list to identify the various components of the VILLA ROOM.

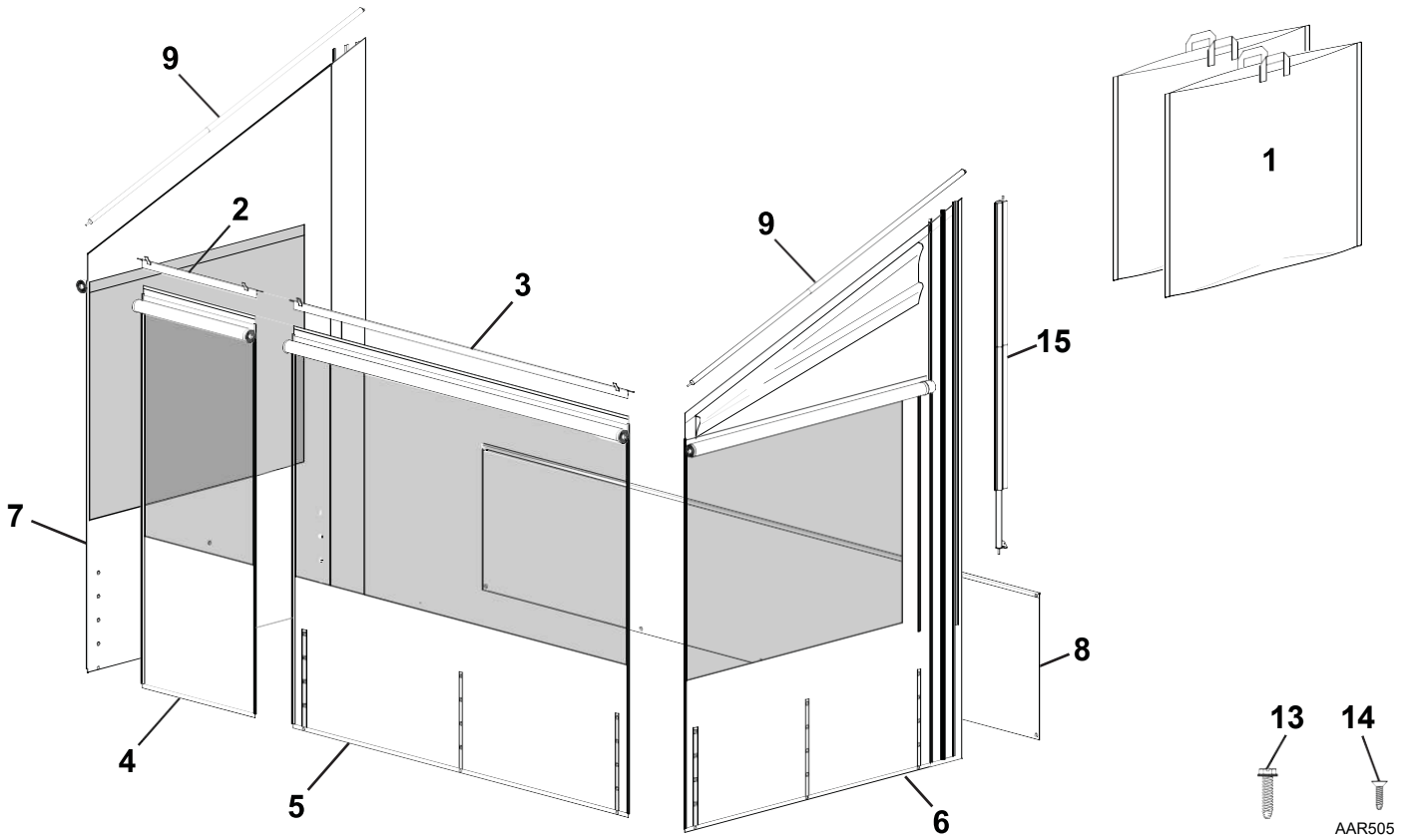

O	ITEM	DESCRIPTION	QTY	NOTE
D	1	Storage Bags, 26" x 36"	2	
D	2	Zipper Insert, Door	1	
D	3	Zipper Insert, Front Panel	1	
D	4	Door Panel	1	
D	5	Front Panel	1	
D	6	Side Panel	1	
D	7	Side Panel	1	
D	8	Skirting Panel	1	
D		Wheel Well Filler, 6'6", Standard Not Shown	1	
D	9	Rafter Assy	2	
D	10	Rafter Bracket	2	
D	14	Screw, Flat Head #6 x 1/2	36	
D	15	Snapless Rafter	2	
D				
D				
D				

LIMITED WARRANTY

Shadepro Inc. warrants to the first retail Purchaser that the Product described in this manual is free of defects in material and workmanship within the terms and conditions as set forth below. Shadepro's obligation under this warranty is limited to the repair or replacement, at Shadepro's option, of any defective component with new or factory refurbished components.

THIS WARRANTY IS NOT TRANSFERABLE.

1. DURATION

- 1.1. One (1) year on parts and standard freight for hardware and fabric.
- 1.2. Warranty duration is not extended by the length of time the product is not in use or the time that the purchaser is deprived the use of the product. Duration of coverage is determined by the date of the original product purchase, not the date of repairs.

2. WHAT IS COVERED UNDER THIS WARRANTY

Defects in the manufacturer's material and workmanship of product under normal use, and which occur within the duration of the warranty period. The following components are covered only as listed:

- 2.1. Fabric – Free from quality defects (normal wear and fading excluded).
- 2.2. Extrusions and Hardware - Free from defects.
- 2.3. Freight - Warranty part order shipments that qualify for freight to be prepaid by Shadepro Ground UPS or by a Common Carrier of Shadepro's choice. Expedited freight is not covered under warranty; customer is responsible for any and all expedited freight charges.

3. WHAT IS NOT COVERED UNDER THIS WARRANTY

- 3.1. Damages not reported at time of purchase/receipt.
- 3.2. Damages or failures not related to the material or workmanship of the product including any failure that results from neglect, accident, wind, rain, water pooling, weather or other acts of God.
- 3.3. Purchaser's abuse, including but not limited to neglect; failure to operate, use or maintain the product in accordance with the instructions provided with the product.
- 3.4. Improper installation and/or any damage/failure that is a result of improper installation or adjustment of the product/component, including fabric damage.
- 3.5. Normal wear, including the occasional need to adjust the product.
- 3.6. Any component not sold or manufactured by Shadepro.
- 3.7. Any incidental, indirect, or consequential loss, damage or expense that may result from any defect, failure, or malfunction of the product.
- 3.8. The removal or alteration of any product component or device. In the event of such removal or alteration, this warranty is void.
- 3.9. Any expense related to delivery or pick-up of product to/from the service dealer; including travel time, transport costs and/or service call charges.

4. RESPONSIBILITIES OF THE PURCHASER

IN ORDER FOR THE WARRANTY TO BE HONORED, THE PURCHASER MUST HAVE PROOF OF PURCHASE: THE ORIGINAL RECEIPT. FAILURE TO PROVIDE THE REQUIRED DOCUMENTATION MAY DELAY OR VOID ANY WARRANTY CLAIM.

- 4.1. Retain dated proof of purchase for specified product, and provide it as requested.
- 4.2. Inspect the room upon purchase/receipt to confirm the condition of the fabric, hardware and operation of product/components.
- 4.3. Perform recommended maintenance as specified in the product literature furnished with the product.
- 4.4. Use reasonable care in the operation, use and storage of the product in accordance with the instructions contained in the product literature furnished with the product.

5. WARRANTY CLAIM PROCEDURE

- 5.1. All returns are for product replacement only. No returns for cash or credit are accepted.
- 5.2. The customer shall pay only those costs not covered by this warranty.
6. THIS WARRANTY GIVES THE OWNER SPECIFIC LEGAL RIGHTS. THE LAWS OF CERTAIN JURISDICTIONS MAY GRANT THE OWNER ADDITIONAL RIGHTS AND PRIVILEGES. Except as set forth above, Shadepro makes no warranty, whether statutory or otherwise, including without limitation, any warranty of merchantability or fitness for a particular purpose. Shadepro shall have no liability except to repair, replace or adjust defective products and parts. Shadepro specifically excludes any liability, whether in contract, tort or otherwise, for personal injury, property damage, economic or consequential losses.
7. Shadepro does not authorize any person or company to alter the terms of this warranty.
8. Shadepro reserves the right to make changes in design and components, without notice, whenever it is believed the quality of the product will be improved, but without incurring any obligation to incorporate such improvements in any product that has been shipped or in service.

Contact us:

Shadepro Inc.
2505 Folex Way
Spring Valley, CA 91978
800-328-5100

customerservice@shadepro.net